

GPU type GB2/3

*Ground Power Unit type GB2/3
3kVA– 115/200V 400Hz
28V_{DC} – 60A – 1300A*



➔ *Diesel engine GPU*

➔ *Transportable in helicopter :
two modules of 85kg each*

Characteristics

AC output	
Rated Power	3kVA
Voltage	115/200V three phases + neutral
Voltage regulation	± 1,5%
Power factor	0,8
Frequency	400 Hz
Frequency regulation	± 3%
DC output	
Rated Power	1,7kW
Permanent current	60A
Peak current	1300A
Voltage	28,5V _{DC}
Voltage regulation	± 0,5V _{DC} from 0 to 60A



GUINAULT SA
PAOS La Saussaye - BP 29
F - 45590 Saint-Cyr en Val
Tél : +33 (0) 2 38 63 84 00
Fax : +33 (0) 2 38 69 66 22
www.guinault.com



Engine

- Lombardini type 15LD315
- Diesel,
- Air cooled
- Speed: 3429 rpm
- 1 cylinder, 315cm³
- Manual and electrical start

Bi-Alternator

- Guinault type AB100
- 400Hz, 115/200V
- 14 poles, brushless
- Electronic voltage regulator Guinault type RS525

Safeties

Electrical

- Over Voltage
- Under Voltage
- Over Frequency
- Under Frequency
- Over Load

Engine

- High Temperature
- Low Oil Pressure

Outputs

- 1 AC output 115/200V-400Hz, length 8 m. + socket ISO461 / Stanag 3303
- 1 DC output 28V_{DC}, length 8 m. + socket ISO461 / Stanag 3302

Main assembly

- Welded tubular frame, anti-corrosion coating
- Inflate tyres
- Cables storage compartments
- Fuel tank 4,3 litres

Options

- Cold start aid

Operation

- Used to start helicopter , to supply 115V/400Hz to avionics devices and charge the aircraft Ni-Cd battery
- Can be separate in two modules (\cong 85kg each) for easier handling and lifting

Dimensions

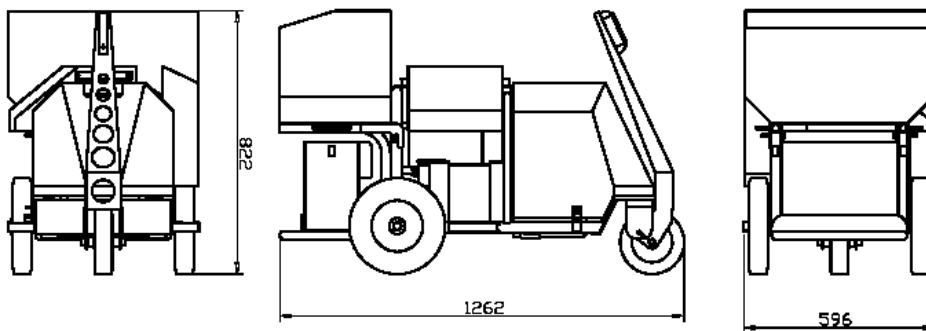

L 1262 x W 596 x H 822 mm

Weight: 170kg (= 87kg + 83kg)



PAOS La Saussaye
F - 45590 Saint-Cyr en Val
Tél : +33 (0) 2 38 63 84 00
Fax : +33 (0) 2 38 69 66 22

info@guinault.com